

Lens Datasheet

Model No: OPLLC0067

LED Source: H35C1

LED Manufacturer: LG INNOTEK

Optics & Allied Engg.Pvt. Ltd.

No. 9Q, 1st Phase, Jigani Link Road,
Bommasandra Industrial Area,

Bangalore, INDIA

Tel: (+91) 80-4904-4904

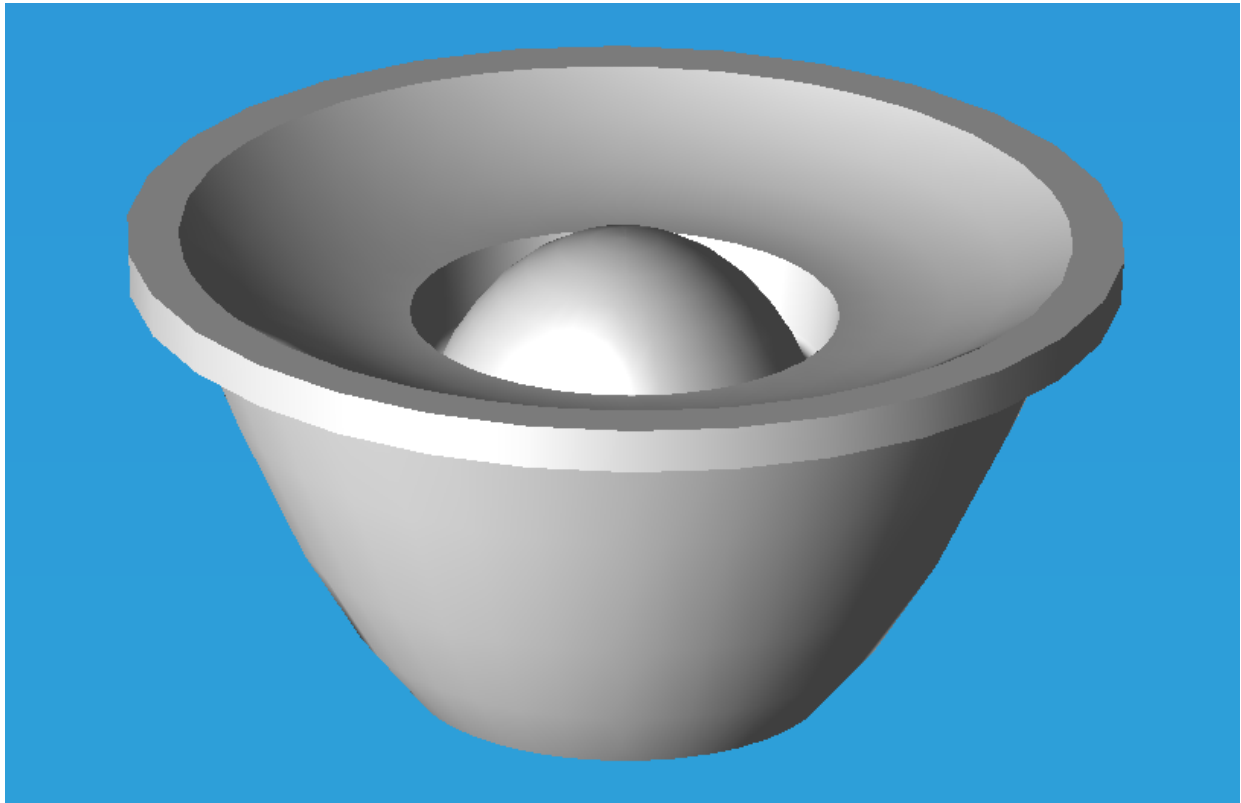

Features:

- High Efficiency
- Narrow beam output
- Easy to mount

Lens Details:

S.No.	Parameter	Specification
1.	Lens Material	PMMA
2.	Lens Dimensions	Ø 32.65mm & Height 15.65mm
3.	Operating Temperature (T _{opr})	-40 to +80°C

Lens Drawing

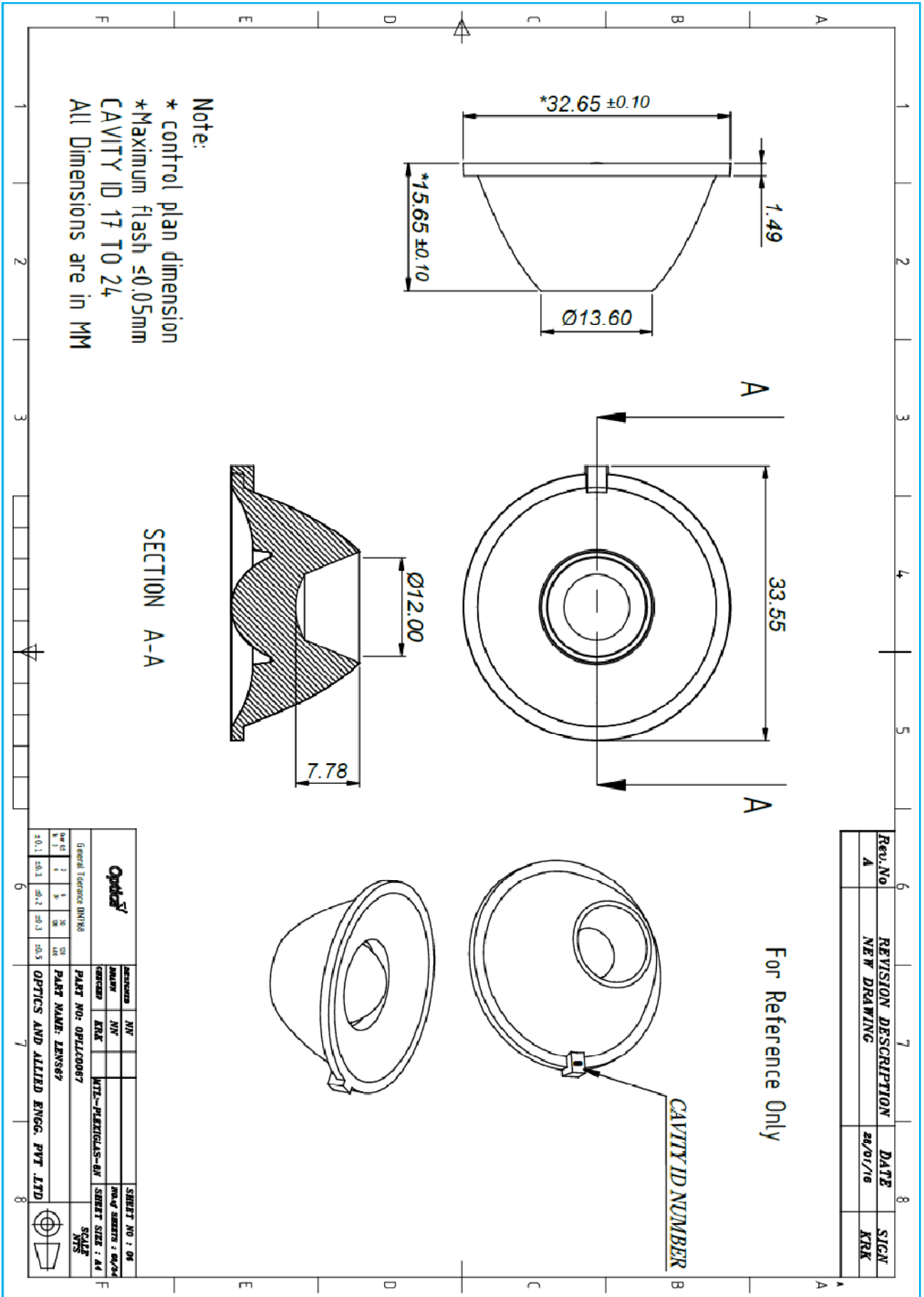

Lens Datasheet

Model No: OPLLC0067

LED Source details:

S.No.	Parameter	Specification
1.	LED Source	H35C1
2.	LED Manufacturer	LG INNOTEK
3.	LED Operating Current	350 mA
4.	Forward Voltage	2.9 V
5.	LED output flux	Normalized to 1 lm
6.	LED viewing angle	120°
7.	Detector distance	2.5 Meter
8.	Simulation Tool	TracePro

Note: Simulation carried out by coupling OPLLC0067 lens with LG INNOTEK H35C1 LED

Polar Intensity Distribution

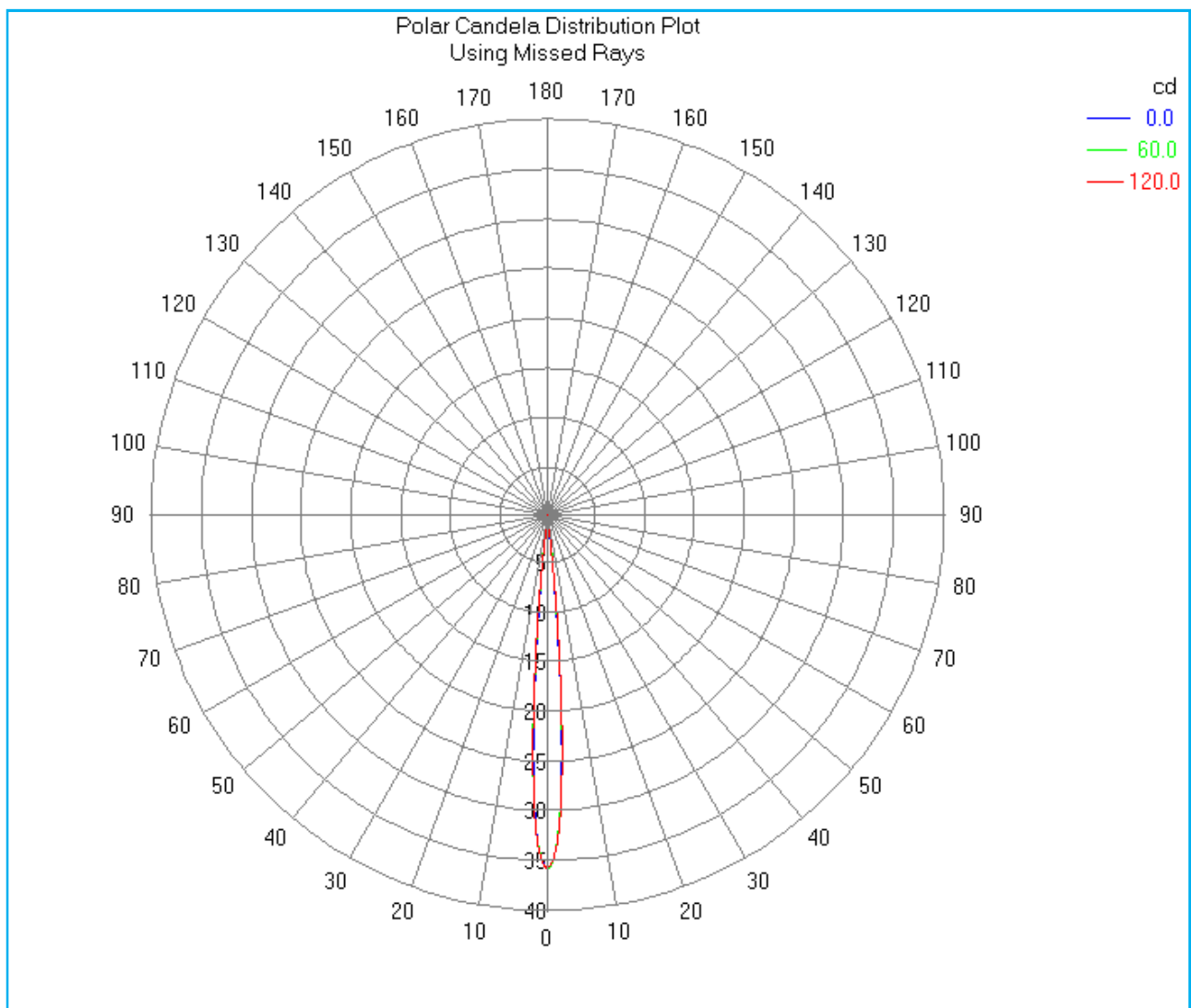

Lens Datasheet
 Model No: OPLLC0067

Rectangular Intensity Distribution

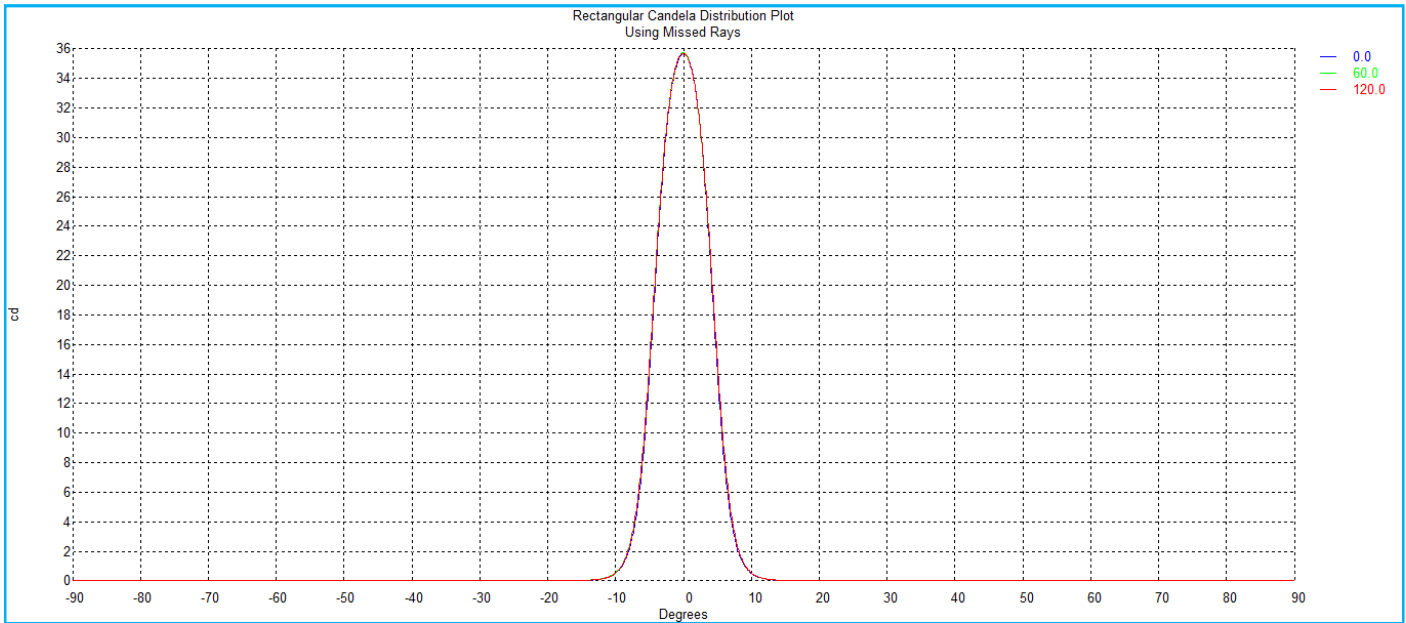

FWHM Angle of the beam is 8.7°
 FWTM Angle of the beam is 14.4°

Note:

FWHM Angle - Full width half maximum (Beam angle at 50% of the maximum Intensity)
 FWTM Angle - Full width tenth maximum (Beam angle at 10% of the maximum Intensity)

Rectangular Iso-Candela Plot

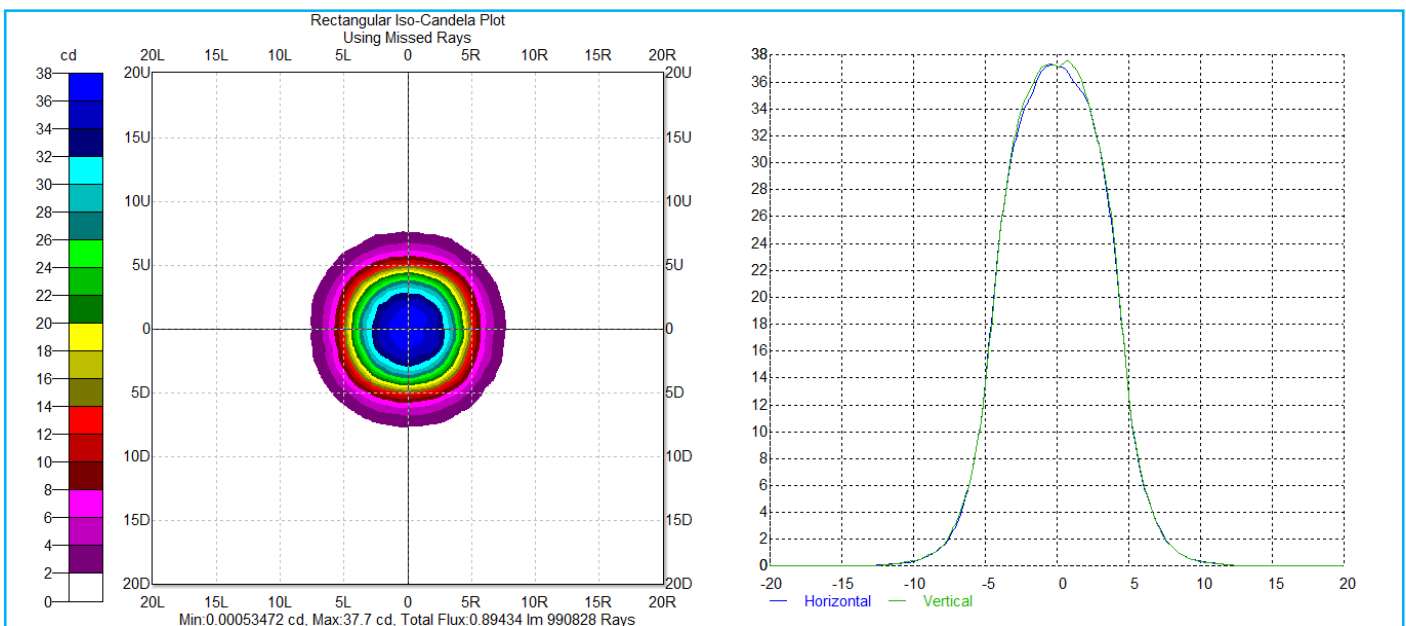

Rectangular Iso-candela plot of the lens with normalized input flux of 1 Lumen

Output flux is 0.895 Lumen

Lens Datasheet

Model No: OPLLC0067

Lens Characteristics

S.No.	Parameter	Value	Units
1.	FWHM Angle of the beam	8.7	Degrees
2.	FWTM Angle of the beam	14.4	Degrees
3.	Efficiency of the lens	90.0	%
4.	Candela per lumen	38.23	Cd/lm

Note:

- Don't handle the lens without wearing the gloves, finger prints may reduce the lens efficiency
- Any flow lines on the external surface of the lens are acceptable if the optical characteristics are not affected